

20 lb ROOF LOAD SIDEWALL OPENING PIER LOAD 16' BOX WIDTH	SIDEWALL OPENING (FT) REQUIRED PIER LOAD (LBS)					
	3	4	5	6	8	10
	1244	1413	1581	1750	2088	2425

*FOR 30 lb & 40 lb ROOF LOAD REFER TO TABLES 7 & 7a IN THE INSTALLATION MANUAL.

PIER LEGEND	
	= PIER MAIN BEAM
	= PIER PERIMETER
	= PIER PORCH/RECESSED ENTRY

SERVICE DROP LEGEND	
	= ELECTRICAL DROP
	= WATER INLET
	= DWV PLUMBING DROP
	= GAS INLET
	= COMMUNICATION/DATA PORT INLET

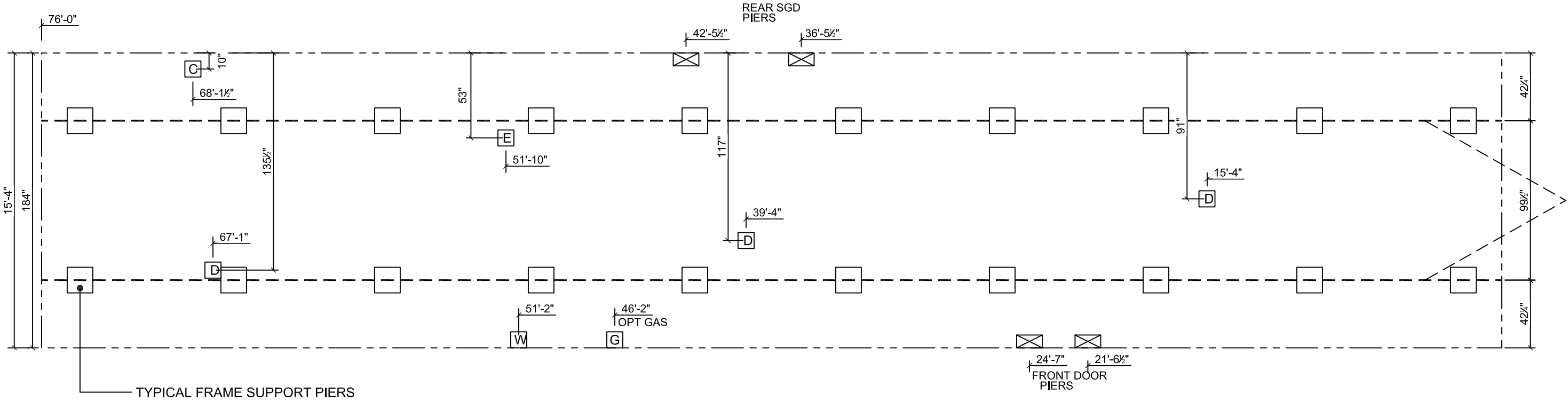

- NOTES:
- REFER TO TABLES 6 AND 6a IN THE INSTALLATION MANUAL FOR LOAD ON FRAME PIER FOOTINGS FOR HOMES THAT DO NOT REQUIRE PERIMETER BLOCKING. REFER TO TABLES 7 AND 7a IN THE INSTALLATION MANUAL FOR LOAD ON FRAME PIER FOOTINGS FOR HOMES THAT REQUIRE PERIMETER BLOCKING. REFER TO TABLES 10 AND 10a TO DETERMINE FOOTING SIZE FOR ALL PIERS.
 - REFER TO TABLE 9 FOR PIER CONFIGURATION AND MAXIMUM ALLOWABLE HEIGHTS. CROSS REFERENCE THE PIER HEIGHT WITH THE MAXIMUM ALLOWABLE FLOOR HEIGHT LISTED IN THE FRAME TIEDOWN CHARTS (TABLE 18, 19, AND 20).
 - THE MAXIMUM SPACING FOR FRAME SUPPORT PIERS FOR 8" I-BEAMS IS 8 FEET, 10" & 12" I-BEAMS IS 10 FEET.
 - SERVICE DROP LOCATIONS IDENTIFIED ARE APPROXIMATE.
 - FLOOR WIDTH SHOWN IS FOR STANDARD PRODUCT ONLY. CONTACT THE MFG FACILITY FOR SPECIFICATIONS OF OPTIONS ORDERED.

<p>MODEL NAME 76' Pinnacle - The Smokey</p> <p>MODEL NO. PCL16763S</p> <p>BOX SIZE 16' x 76'</p> <p>MODEL SQ. FT. 1,165</p>	<table border="1" style="width: 100%; border-collapse: collapse;"> <tr> <th>REVISION</th> <th>DATE</th> </tr> <tr> <td> </td> <td> </td> </tr> <tr> <td> </td> <td> </td> </tr> <tr> <td> </td> <td> </td> </tr> <tr> <td> </td> <td> </td> </tr> </table> <p>DRAWN BY Parker Merritt</p> <p>DATE DRAWN 11/25/2025</p> <p>DATE PRINTED 1/23/2026</p> <p>SCALE 3/16"=1'</p> <p>PLAN NO. 22s179</p> <p>SHEET NAME FRAME PIERS</p> <p>SHEET NO. SU-1.</p>	REVISION	DATE								
REVISION	DATE										